



## GPSMAP® 4000/5000 Series Installation Instructions

The GPSMAP 4000/5000 series chartplotter and GPS antenna must be properly installed according to the following instructions. You need the appropriate fasteners, tools, and mounts listed in each section. These items are available at most marine dealers. Always wear safety goggles, ear protection, and a dust mask when drilling, cutting, or sanding. When drilling or cutting, always check what is on the opposite side of the surface. Mount the GPSMAP 4000/5000 series chartplotter in a location that provides a clear, glare-free view of the display and easy operation of the controls or touch screen. **If you experience difficulty installing the chartplotter, seek the assistance of a professional installer; or contact Garmin Product Support by phone at 913/397.8200 or 800/800.1020. Go to [www.garmin.com/support](http://www.garmin.com/support). In Europe, contact Garmin (Europe) Ltd. at 44/0870.8501241.**

Before installing your GPSMAP 4000/5000 series chartplotter, confirm that the package contains the items listed on the box. If any parts are missing, contact your Garmin dealer immediately.

**WARNING:** See the *Important Safety and Product Information* guide in the product box for product warnings and other important information.

### To install the GPSMAP 4000/5000 series chartplotter, you must:

1. Mount the GPSMAP 4000/5000 series chartplotter ([page 1](#)).
2. Mount the GPS antenna ([page 5](#)).
3. Connect the GPSMAP 4000/5000 series device to power and to the GPS antenna ([pages 9–10](#)).
4. Ensure the chartplotter software is up-to-date ([page 20](#)).

### Although they are not necessary to use the GPSMAP 4000/5000 chartplotter, this manual covers other installation options:

- Connecting the chartplotter to other Garmin Marine Network compatible devices, such as a sounder or a radar ([page 12](#)).
- Connecting the chartplotter to an existing NMEA 2000 network ([page 10](#)).
- Connecting the chartplotter to other NMEA 0183-compatible devices such as a VHF radio with DSC ([page 15](#)).
- Connecting the chartplotter to an external alarm ([page 18](#)).
- Connecting the chartplotter to a video input source ([page 19](#)).
- Connecting the chartplotter to an external video monitor ([page 19](#)).

## Mounting the GPSMAP 4000/5000 Series Chartplotter

You can mount the GPSMAP 4000/5000 series chartplotters one of two ways. You can use the included bracket to bail mount the chartplotter, or you can use the included template and hardware to flush mount the chartplotter.



**NOTE:** You cannot bail mount the GPSMAP 5015/5215 chartplotters. Because of the larger size, you must flush mount a GPSMAP 5015/5215 chartplotter.

### Bail Mounting the GPSMAP 4000/5000 Series Chartplotter

Use the included bracket to bail mount the GPSMAP 4000/5000 series chartplotter.

#### Tools required (not included):

- Drill and drill bit
- Screwdriver
- Pencil
- Mounting hardware (screws or nuts, washers, and bolts)



**NOTE:** The mounting hardware (screws or nuts, washers, and bolts) are not included. The holes on the bail mount are  $\frac{5}{16}$  in. (7.9 mm) in diameter. Choose mounting hardware that fits the holes in the bail mount and securely attaches it to your specific mounting surface. The size of the drill bit required depends on the mounting hardware chosen.

### To install the bail-mount bracket ①:

**NOTE:** You cannot bail mount the GPSMAP 5015/5215 chartplotters. Because of the larger size, you must flush mount the GPSMAP 5015/5215 chartplotter.

1. Using the bail mount as a template, mark the location of the four mounting holes. Be sure to leave at least 5 in. (12.7 cm) of clearance behind the 4000/5000 series chartplotter for the wiring.

**NOTE:** Mount a GPSMAP 4008/4208/5008/5208 chartplotter 31 1/2 in. (80 cm), and a GPSMAP 4010/4210/4012/4212/5012/5212 chartplotter 39 3/8 in. (1 m) from a magnetic compass to avoid interference.

2. Using an appropriately sized drill bit, drill the pilot holes for your mounting hardware.
3. Secure the bail mount to the surface with your mounting hardware.

### To install the GPSMAP 4000/5000 series chartplotter on the bail-mount bracket ②:

1. Loosely attach the mounting knobs to the GPSMAP 4000/5000 series chartplotter.
2. Slide the chartplotter onto the bail mount, and tighten the mounting knobs.

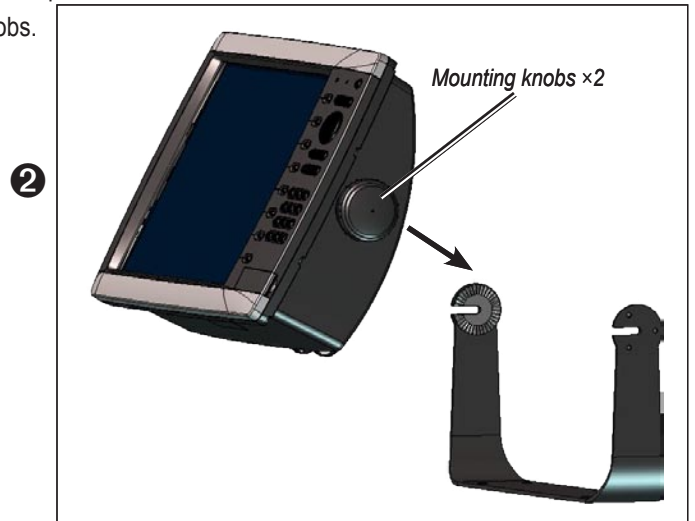
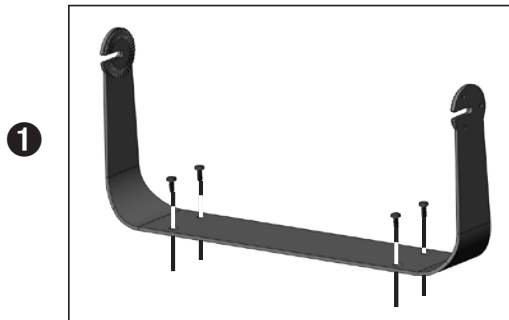

## Flush Mounting the GPSMAP 4000/5000 Series Chartplotter

The flush-mount method you will use with your chartplotter is dependent on the model. Be sure to follow the instructions for your chartplotter model.

### Flush Mounting a GPSMAP 4008/4208/4012/4212 Chartplotter or a GPSMAP 5008/5208/5012/5212 Chartplotter

#### Hardware (included):

- Flush-mount template
- Rubber gasket
- Four threaded 4 mm mounting studs
- Four 4-mm flat washers
- Four 4-mm lock washers
- Four 4-mm nuts

#### Tools required (not included):

- Jigsaw
- Masking tape
- Scissors
- Drill
- Drill bits—3/8 in. (10 mm) and 4 mm
- 1/16 in. (2 mm) Allen (Hex) wrench
- 4 mm socket or wrench
- Center punch and hammer

**To flush mount a GPSMAP 4008/4208/4012/4212 chartplotter or a GPSMAP 5008/5208/5012/5212 chartplotter:**

1. The flush-mount template is included in the product box. Trim the template and ensure it will fit in the location at which you want to flush mount the chartplotter.

**NOTE:** Make sure the surface on which you mount the chartplotter has at least 7 in. (18 cm) of open space behind it to fit the chartplotter and the connected wires.

**NOTE:** Make sure to leave approximately 1/2 in. (13 mm) of space on the right side of the chartplotter to access the SD card door.

**NOTE:** Mount a 4008/4208/5008/5208 chartplotter 31 1/2 in. (80 cm), and a 4012/4212/5012/5212 chartplotter 39 3/8 in. (1 m) from a magnetic compass to avoid interference.

2. The flush-mount template has adhesive on the back. Remove the protective liner and apply the template to the location at which you want to mount the chartplotter.
3. Using a 3/8 in. (10 mm) drill bit, drill one or more of the four pilot holes inside the corner of the template to begin cutting the mounting surface.
4. Using the jigsaw, cut the mounting surface along the inside of the solid line indicated on the flush-mount template. Use a file and sandpaper to refine the size of the hole. **Be very careful when cutting this hole. There is only a small amount of clearance between the case and the mounting holes.**
5. Install the four mounting studs into the chartplotter by screwing the shorter, threaded section into the back of the chartplotter. Use the 1/16 in. (2 mm) Allen wrench to tighten the mounting studs until they stop. **Do not overtighten - you may damage the mounting stud or the mounting holes.** The studs are coated with a reusable thread-locking patch applied at the factory.
6. Place the chartplotter in the hole and make sure that the mounting studs line up with the pilot holes on the flush-mount template after cutting, sanding, and filing the hole. If they do not, mark the locations where the studs will feed through the mounting surface.
7. Using the center punch, indent the center of each of the 4 mm mounting-hole locations.
8. Using a 4 mm drill bit, drill the four mounting holes.
9. Install the rubber gasket on the back of the chartplotter. The top and bottom sections will line up with the holes. The side sections will line up with the notches in the case (for the cover)
10. Place the chartplotter into the cutout. The four mounting studs should feed through the four mounting holes drilled in step 8.
11. Place the flat washers and the lock washers over the mounting studs. Then thread the hex nuts onto the mounting studs. Tighten all four hex nuts evenly until the chartplotter is snug against the mounting surface.

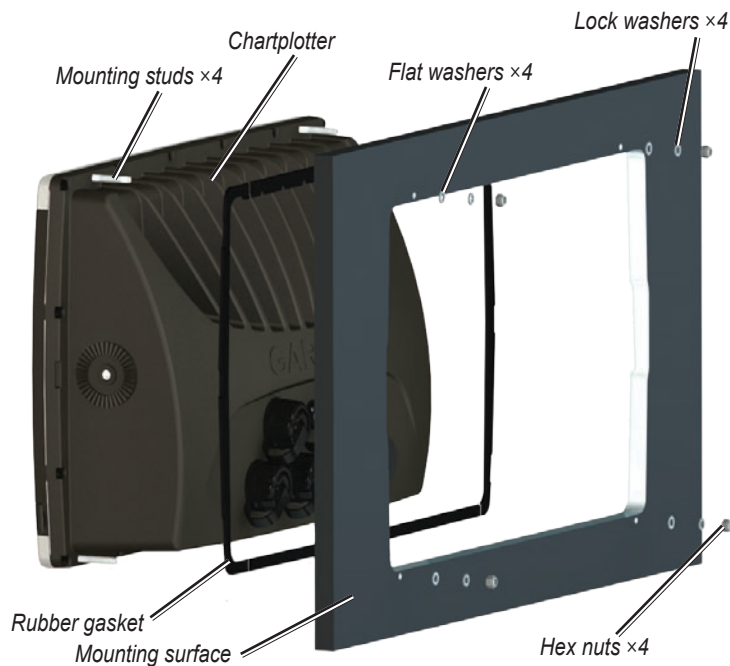

**Flush Mounting a GPSMAP 4008/4208/4012/4212/5008/5208/5012/5212 Chartplotter**

## Flush Mounting a GPSMAP 4010/4210 Chartplotter or a GPSMAP 5015/5215 Chartplotter:

### Hardware (included):

- Flush-mount template
- Rubber gasket
- Mounting screws (4.2 × 1.4 DIN7981 / number 8 ANSI)

### Tools required (not included):

- Jigsaw
- Masking tape
- Scissors
- Drill
- Drill bits— $\frac{3}{8}$  in. (10 mm), also see drill size table
- Center punch and hammer
- Anti-sieze lubricant (optional)

### To flush mount a GPSMAP 4010/4012 chartplotter or a GPSMAP 5015/5215 chartplotter:

1. The flush-mount template is included in the product box. Trim the template and ensure it will fit in the location where you want to flush mount the chartplotter.

**NOTE:** Make sure the surface on which you mount the chartplotter has at least 7 in. (18 cm) of open space behind it to fit the chartplotter and the connected wires, and make sure to leave approximately  $\frac{1}{2}$  in. (13 mm) of space on the right side of the chartplotter to access the SD card door.

**NOTE:** Mount a 4010/4210 chartplotter 31  $\frac{1}{2}$  in. (80 cm), and a 5015/5215 chartplotter 23  $\frac{5}{8}$  in. (60 cm), from a magnetic compass to avoid interference.

2. The flush-mount template has adhesive on the back. Remove the protective liner and apply the template to the location at which you want to mount the chartplotter.
3. Using a  $\frac{3}{8}$  in. (10 mm) drill bit, drill a pilot hole inside the corner of the template to begin cutting the mounting surface.
4. Using the jigsaw, cut the mounting surface along the inside of the solid line indicated on the flush-mount template. Use a file and sandpaper to refine the size of the hole.
5. If the top and bottom mounting covers are attached to the front of the chartplotter, remove them by unsnapping the covers from the sides.
6. Place the chartplotter in the hole, and make sure that the mounting holes on the chartplotter line up with the pilot holes on the flush-mount template after cutting, sanding, and filing the hole. If they do not, mark the locations where the pilot holes need to be.
7. Using the center punch, indent the center of each of the mounting-hole locations.
8. Using a drill bit as specified by the Pilot Hole Size Table, drill the mounting holes.



Material	Material Thickness (in.)	Material Thickness (mm)	Hole Size (in.)	Hole Size (mm)	Hole Size (Drill Number)
Aluminum alloy sheet metal	from $\frac{1}{32}$ to $\frac{5}{64}$	from 0.76 to 2.03	.128	3.25	30
	from $\frac{3}{32}$ to $\frac{3}{8}$	from 2.28 to 9.52	.147	3.73	26
Fiberglass—all thicknesses			.140	3.56	28
High Density Plastic—all thicknesses			.125	3.17	$\frac{1}{8}$
Plywood (resin impregnated)—Professional installation recommended			.144	3.66	27

**Pilot Hole Size Table**

**NOTE:** If you are mounting the chartplotter in fiberglass, it is recommended to use a countersink bit to drill a clearance-counterbore through only the top gel-coat layer. This will help to avoid any cracking in the gel-coat layer when the screws are tightened

9. Install the rubber gasket on the back of the chartplotter. The top and bottom sections will line up with the holes. The side sections will line up with the notches in the case for the sun cover.
10. Place the chartplotter into the cutout.
11. Securely tighten the included mounting screws through the chartplotter into the pilot holes.

**NOTE:** Stainless-steel screws may bind when screwed into fiberglass and overtightened. Garmin recommends applying an anti-galling, stainless anti-sieze lubricant to the screw before using.

12. Replace the mounting covers by snapping them into place.

## Mounting the GPS Antenna

You have one of two types of GPS antennas in your product box. Use the illustrations to identify the included antenna and follow the correct installation procedures.

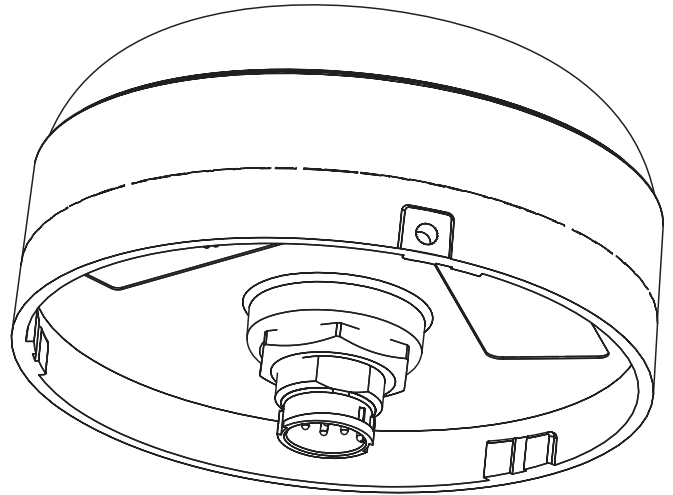
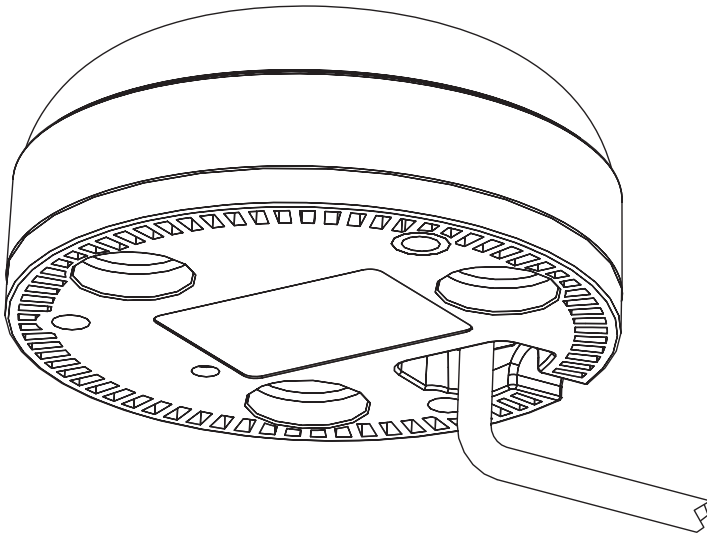

### GPS 17

- Can be surface mounted or pole mounted. See [page 6](#).
- Uses a separate template for surface mounting. See [page 23](#).
- Connects to the chartplotter using NMEA 0183. See [page 9](#).

### GPS 17x

- Can be surface mounted, pole mounted, or mounted under a fiberglass surface. See [page 7](#).
- Does not use a separate template for surface mounting. See [page 7](#).
- Connects to the chartplotter using NMEA 2000. See [page 10](#).



**CAUTION:** Be sure to follow the correct mounting directions and the correct wiring directions for the antenna included with your chartplotter.

## Choosing a location for the GPS antenna

You can surface mount the GPS 17 and GPS 17x antennas, attach them to a standard 1 in. OD pipe-threaded-pole marine mount (14 threads-per-inch—not included), or even install a GPS 17x antenna under fiberglass.

Select a suitable location for the GPS antenna on your boat. To ensure the best reception, mount the GPS antenna in a location that has a clear, unobstructed view of the sky in all directions.

- Avoid mounting the GPS antenna where it is shaded by the superstructure of the boat, a radome antenna, or mast.
- On a sailboat, avoid mounting the GPS antenna high on the mast, to prevent inaccurate speed readings caused by excessive heeling.
- The GPS antenna provides more-stable readings when located nearer to water level.
- **Mount the GPS antenna at least 3 ft. (1 m) away from (preferably above) the path of any radar beam or a VHF radio antenna.**
- Temporarily secure the antenna in the preferred mounting location and test it for correct operation. If you experience interference with other electronics, try a different location. When you verify correct operation, permanently mount the antenna.

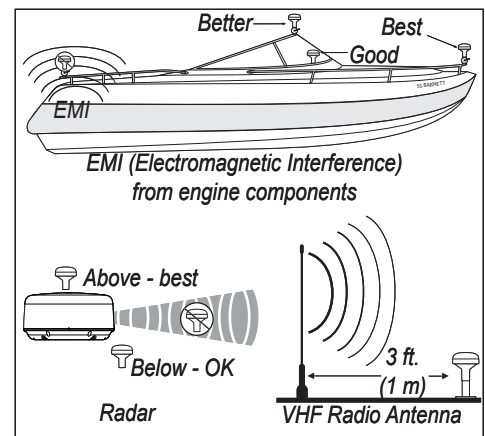

**GPS 17x Placement Considerations**

## Mounting a GPS 17 Antenna

You can surface mount the GPS 17 antenna or install it on a standard 1 in. OD pipe-threaded-pole marine mount (14 threads per inch—not included).

### Surface Mounting the GPS 17 Antenna

1. Cut out the Surface Mount Drilling Template provided on [page 23](#), and tape it on the selected mounting location.
2. Mark the center of each mounting hole with a center punch and a hammer. If you plan to run the cable through the mounting surface, mark the center of the additional, larger hole indicated on the template.
3. Drill the mounting holes using a  $1\frac{1}{64}$  in. (4.5 mm) drill bit. If you plan to run the cable through the mounting surface, drill the larger hole using a  $\frac{3}{4}$  in. (19 mm) drill bit.
4. If you are routing the cable through the mounting surface, feed it through the larger hole, and apply marine sealant to the outside exit area.
5. Align the GPS 17 over the mounting holes, and fasten it using M4 screws (not included). The mounting threads in the GPS 17 are 8.10 mm deep. Use screws of a proper length for the mounting surface, which do not thread into the GPS 17 deeper than 8 mm. Screws that thread deeper than 8 mm may damage the case.

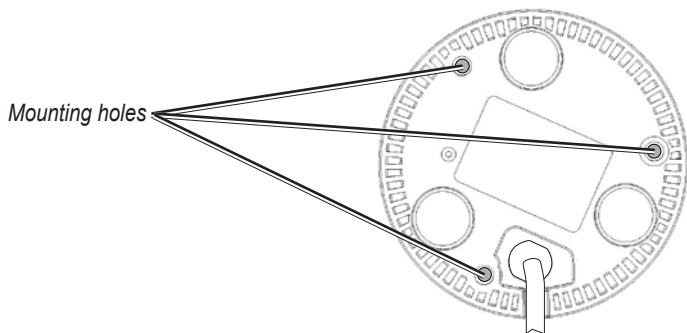

Bottom of GPS 17 Antenna



*When installing the GPS 17, you can run the power/data cable through the mounting surface or outside of the unit. If the power/data cable is run through the mounting surface, seal the outside exit area with marine sealant.*

### Pole Mounting the GPS 17 Antenna

To attach the enclosed pole-mount adapter to the GPS 17:

1. Thread the cable through the pole-mount adapter.
2. Align the tab on the pole-mount adapter to the notch on the GPS 17.
3. Use the included screws to secure the pole-mount adapter to the base of the GPS 17.

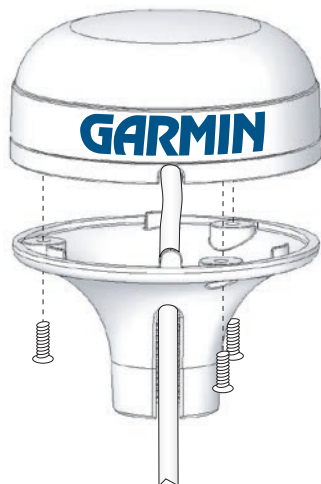

Attaching the Pole-mount Adapter to the GPS 17

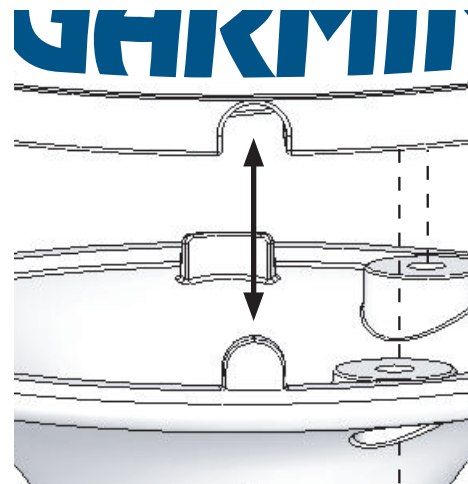

Align Notch

### To mount the GPS 17 with the cable run outside the mount:

1. Place the cable in the vertical slot along the base of the assembled GPS 17 and pole-mount adapter.
2. Screw the assembled GPS 17 and pole-mount adapter onto a standard 1 in. OD pipe-threaded-pole marine mount (14 threads per inch—not included). **DO NOT overtighten pole-mount adapter.** Overtightening the pole-mount adapter may cut the cable.
3. With the GPS 17 installed on the pole mount, fill the remaining gap in the cable exit with a marine sealant.
4. Fasten the pole mount to the boat if it is not already attached.
5. Route the cable away from sources of electronic interference, and connect it to your chartplotter.

### To mount the GPS 17 with the cable run through the mount:

1. Position a standard 1 in. OD pipe-threaded-pole marine mount (14 threads per inch—not included) in the preferred location, and mark the approximate center of the mount.
2. Drill a hole using a  $\frac{3}{4}$  in. (19 mm) drill bit for the cable to pass through.
3. Fasten the pole mount to the boat .
4. Slide the cable through the pole mount and screw the assembled GPS 17 and pole-mount adapter onto the pole mount.
5. Route the cable away from sources of electronic interference, and connect it to your chartplotter.

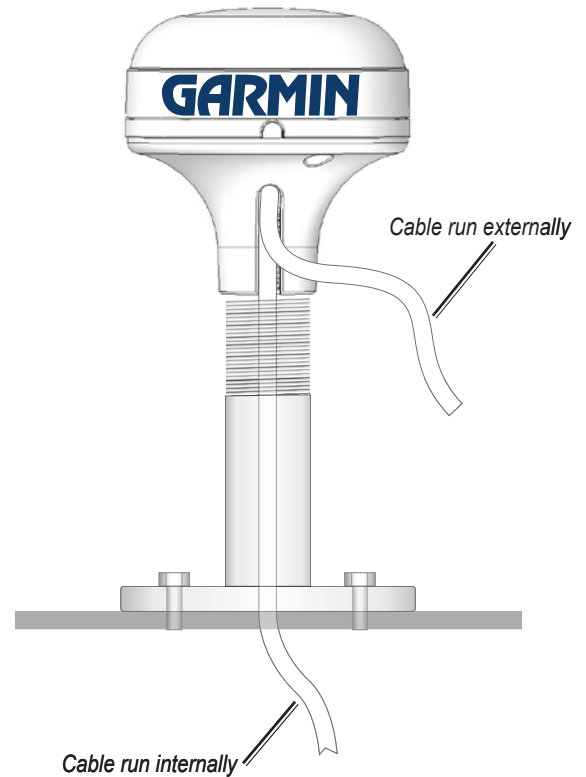

**Attaching the GPS 17 to a Pole Mount**

## Mounting a GPS 17x Antenna

The GPS 17x antenna can be surface mounted, installed on a standard 1 in. OD pipe-threaded-pole marine mount (14 threads-per-inch—not included), or even mounted under fiberglass.

### Surface-mounting the GPS 17x Antenna

1. Use the surface-mount bracket as your mounting template.
  - Use the center punch to mark the three screw locations on the surface.
  - Use a pencil to trace the cable hole in the center of the bracket.
  - Set the surface-mount bracket aside. Do not drill through the surface-mount bracket.
2. Select the appropriate drill bit for your mounting surface using the drill bit table ([page 4](#)), and drill the three pilot holes.

**NOTE:** If you are mounting the GPS 17x on fiberglass, it is recommended to use a countersink bit to drill a clearance counterbore through the top gelcoat layer (but no deeper). This will help to avoid cracking in the gelcoat layer when the screws are tightened.

3. Use a 1 in. (25 mm) hole saw to cut the cable hole in the center.
4. Place the seal pad on the bottom of the surface-mount bracket. Make sure that the screw holes align.
5. Use the included M4 screws to attach the surface-mount bracket to the mounting surface.
6. Route the NMEA 2000 cable through the 1 in. (25 mm) cable hole and connect it to the GPS 17x.
7. Make sure the large gasket is in place on the bottom of the GPS 17x antenna, place the antenna on the surface-mount bracket ❶, and twist it clockwise to lock it in place ❷.
8. Secure the antenna to the mounting bracket with the included M3 set screw ❸.
9. Route the NMEA 2000 cable away from sources of electronic interference, and connect it to your NMEA 2000 network.

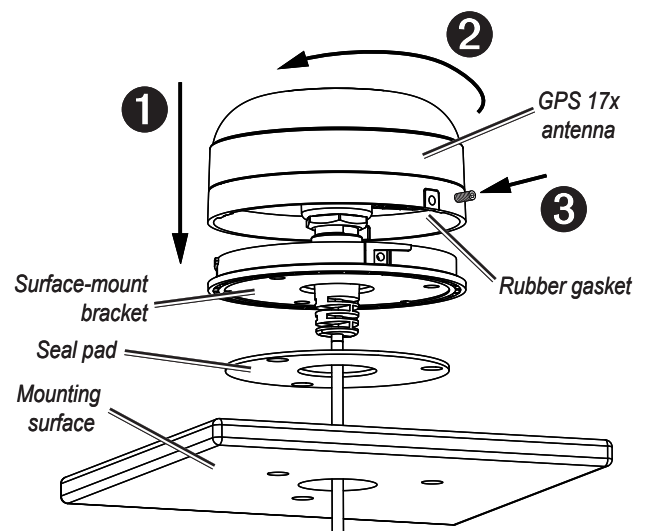

## Pole Mounting the GPS 17x Antenna

With the pole-mount adapter attached to the GPS 17x, you can install the GPS 17x on a standard 1 in. OD pipe-threaded-pole marine mount (14 threads per inch—not included). You can run the NMEA 2000 cable through the pole or outside the pole.

### To mount the GPS 17x with the cable run outside the pole:

1. Route the NMEA 2000 drop cable through the pole-mount adapter, and place the cable in the vertical slot along the base of the pole-mount adapter.
2. Thread the pole-mount adapter onto a standard 1 in. OD pipe-threaded-pole marine mount (14 threads per inch—not included). Do not overtighten the adapter.
3. Connect the NMEA 2000 drop cable to the GPS 17x antenna.
4. Place the GPS 17x antenna on the pole-mount adapter ❶ and twist it clockwise to lock it in place ❷.
5. Secure the antenna to the adapter with the included M3 set screw ❸.
6. (Optional) With the GPS 17x installed on the pole mount, fill the remaining gap in the vertical cable slot with a marine sealant.
7. Attach the marine mount to the boat if it is not already attached.
8. Route the cable away from sources of electronic interference, and connect it to your NMEA 2000 network.

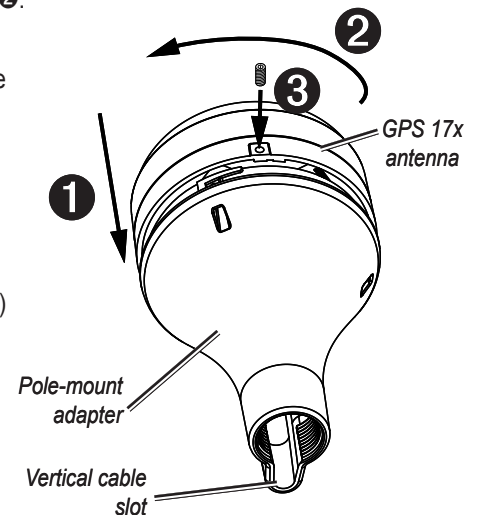

### To mount the GPS 17x with the cable run through the pole:

1. Position a standard 1 in. OD pipe-threaded-pole marine mount (14 threads per inch—not included) in the preferred location, and mark the approximate center of the pole.
2. Drill a hole using a  $\frac{3}{4}$  in. (19 mm) drill bit for the cable to pass through.
3. Fasten the marine mount to the boat.
4. Thread the pole-mount adapter onto the pole. Do not overtighten the adapter.
5. Route the NMEA 2000 drop cable through the pole and connect it to the GPS 17x antenna.
6. Place the GPS 17x antenna on the pole-mount adapter ❶ and twist it clockwise to lock it in place ❷.
7. Secure the antenna to the adapter with the included M3 set screw ❸.
8. (Optional) With the GPS 17x installed on the pole mount, fill the vertical cable slot with a marine sealant.
9. Route the cable away from sources of electronic interference, and connect it to your NMEA 2000 network.

## Under-deck-mounting the GPS 17x Antenna

The GPS 17x can be mounted under a fiberglass surface with the included adhesive pads. The GPS 17x will not acquire satellite signals through metal—you can only use the under-deck mount under a fiberglass surface.

1. Determine the location on the fiberglass surface where you want to mount the GPS 17x.

2. Place the adhesive pads on the under-deck mounting bracket.

There are holes in the under-deck mounting bracket that can be used to secure the under-deck mount to the mounting surface with screws. Garmin does not recommend attaching the under-deck mounting bracket to the surface with screws, because of the likelihood that screws will extend beyond the top of the mounting surface. If you choose to use screws, do so with extreme care.

3. Place the GPS 17x in the under-deck mounting bracket.
4. Adhere the under-deck mounting bracket to the mounting surface.
5. Connect the NMEA 2000 drop cable to the GPS 17x.
6. Route the cable away from sources of electronic interference, and connect it to your NMEA 2000 network.

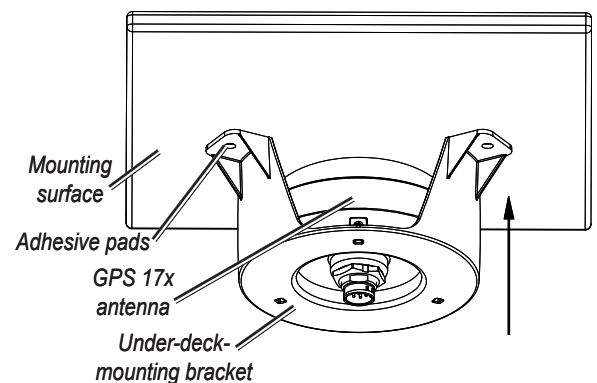

# Wiring and Cables

The GPSMAP 4000/5000 series chartplotter comes with a power cable, a NMEA 2000 drop cable, a 19-pin NMEA 0183 data cable, and a 17-pin Marine Video cable. Optional Garmin Marine Network components use specialized Garmin Network cables. Depending on the installation, it may be necessary to drill holes to route the connector end of these cables.

Garmin rubber grommets are provided to cover these holes for a finished look.

You may not need the grommets in some installations. The grommets do NOT create a waterproof seal. Apply a marine sealant around the grommet and cable after installation. Be sure to test the system before installing and sealing the grommets. Purchase additional grommets from your Garmin dealer or directly from Garmin at [www.garmin.com](http://www.garmin.com).

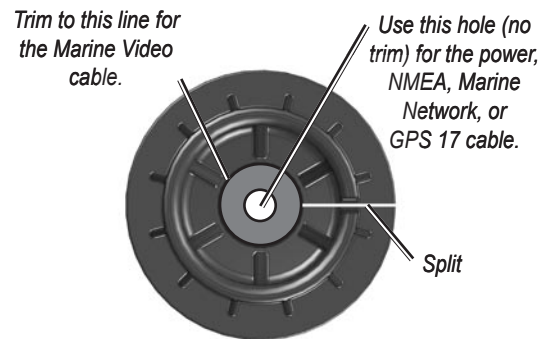

## Tools

- Drill
- 1 1/4 in. (31.7 mm) paddle drill bit or hole saw
- Utility knife
- Marine sealant (optional)

## To install the cable grommet:

1. Mark the location where you want to route the cable (power, NMEA 0183, NMEA 2000 Marine Video, or Marine Network.)
2. Using a 1 1/4 in. (31.7 mm) paddle drill bit or hole saw, drill the installation hole.
3. Refer to the diagram for trimming instructions. Carefully trim the cable hole in the grommet, as needed.
4. Route the cable to the chartplotter, and test the system.
5. Spread the grommet apart at the split and place it around the cable.
6. Firmly push the grommet into the installation hole until it is seated. Apply marine sealant, as needed, to weatherproof the cable.

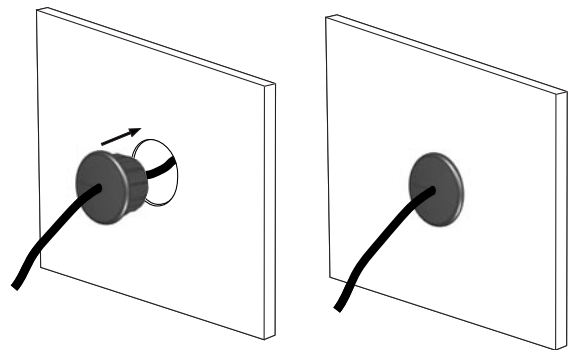

## Wiring the Power Cable

The GPSMAP 4000/5000 series chartplotter must be connected to the power supply for the boat. Use the 2-pin power cable included, and connect the power (red) and ground (black) wires. Use 14 AWG shielded wiring for extended runs of wire to the power cable. Solder all connections and seal them with heat-shrink tubing.

## Wiring the GPS 17 Antenna

The GPS 17 antenna must be wired to the included 19-pin NMEA 0183 cable as well as to the power supply for the boat. Refer to the diagram below when wiring the GPS 17 to the 19-pin NMEA 0183 cable. Use 22 AWG shielded wiring for extended runs of wire to the NMEA 0183 cable or GPS 17 cable. Solder all connections and seal them with heat-shrink tubing.

**NOTE:** If you are using more than one Garmin chartplotter over a Garmin Marine Network, do not wire more than one chartplotter to a GPS antenna. The GPS signal is shared between multiple chartplotters connected to a Garmin Marine Network.

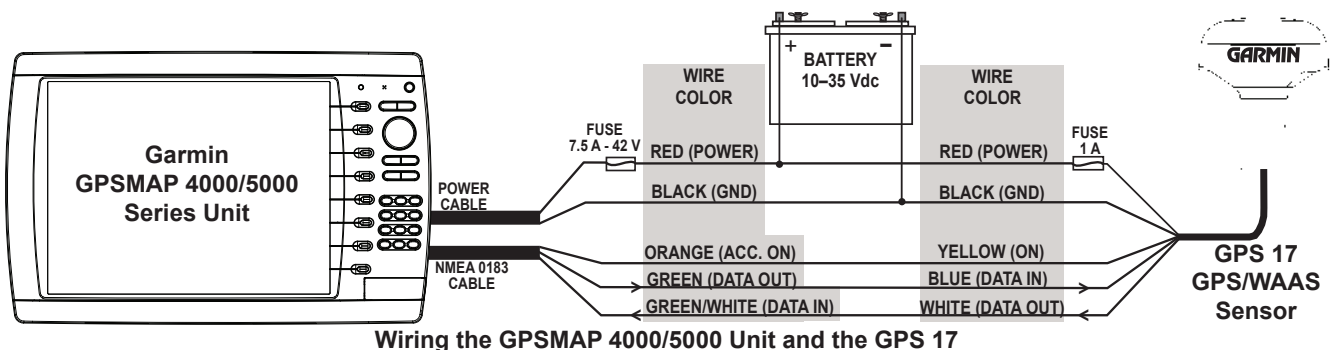

Wiring the GPSMAP 4000/5000 Unit and the GPS 17

# Connecting the GPSMAP 4000/5000 Series Chartplotter and the GPS 17x Antenna to Your NMEA 2000 Network

The GPSMAP 4000/5000 series chartplotter is packaged with the necessary NMEA 2000 connectors and cable to either connect the GPSMAP 4000/5000 series chartplotter and GPS 17x antenna to your existing NMEA 2000 network, or to build a basic NMEA 2000 network. For more information on NMEA 2000, visit [www.garmin.com](http://www.garmin.com).

## Connecting to an Existing NMEA 2000 network

If your boat already has a NMEA 2000 network installed, use the included T-connectors and drop cable to connect the GPSMAP 4000/5000 series chartplotter and GPS 17x antenna to the existing network.

### To connect the GPSMAP 4000/5000 series chartplotter and GPS 17x to your existing NMEA 2000 network:

1. Determine the appropriate locations to connect the GPSMAP 4000/5000 series chartplotter and GPS 17x to your existing NMEA 2000 backbone.
2. Disconnect one side of a NMEA 2000 T-connector from the backbone nearest to the location where you want to connect the chartplotter.

If you need to extend the NMEA 2000 backbone, connect an appropriate NMEA 2000 backbone extension cable (not included) to the side of the T-connector you disconnected.

3. Connect an included T-connector in the NMEA 2000 backbone (for the chartplotter).
4. Route an included drop cable to the chartplotter and to the top of the T-connector you added to your NMEA 2000 network.

If the included drop cable is not long enough, you can add a drop cable extension up to 13 ft. (4 m). If more cable is needed, add an extension to your NMEA 2000 backbone, based on the NMEA 2000 guidelines.

5. Disconnect one side of a NMEA 2000 T-connector from the backbone nearest to the location where you want to connect the GPS 17x antenna.

If you need to extend the NMEA 2000 backbone, connect an appropriate NMEA 2000 backbone extension cable (not included) to the side of the T-connector you disconnected.

6. Connect an included T-connector in the NMEA 2000 backbone (for the GPS 17x antenna).
7. Route an included drop cable from the GPS 17x antenna to the top of the T-connector you added to your NMEA 2000 network.

If the included drop cable is not long enough, you can add a drop cable extension up to 13 ft. (4 m). If more cable is needed, add an extension to your NMEA 2000 backbone, based on the NMEA 2000 guidelines.

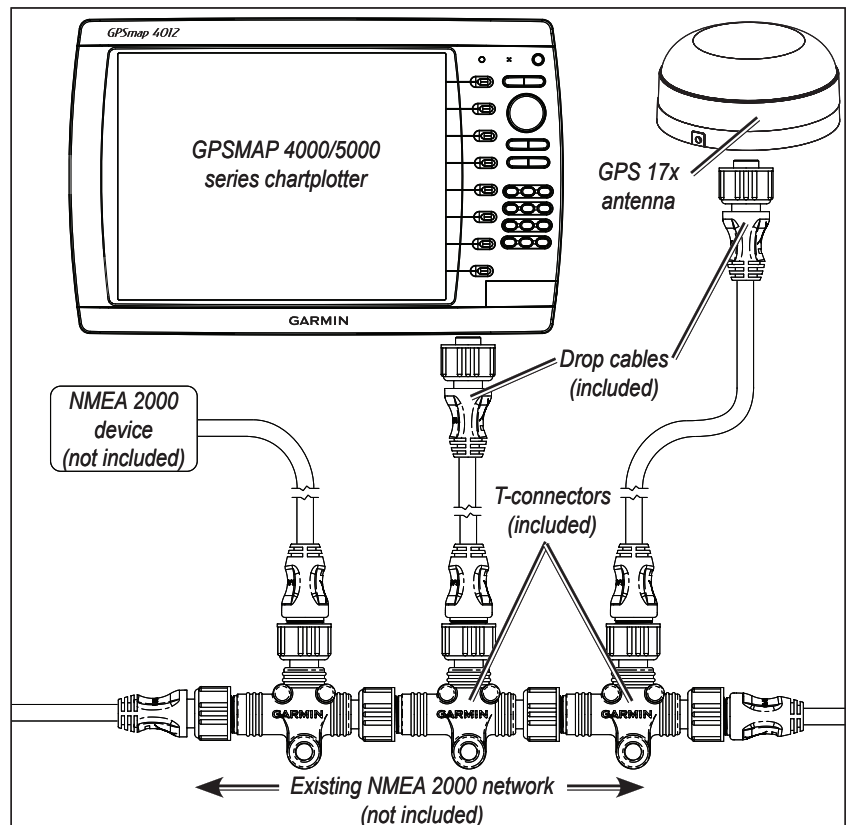

Connecting the GPSMAP 4000/5000 Series Chartplotter and GPS 17x Antenna to an Existing NMEA 2000 Network

**CAUTION:** If you have an existing NMEA 2000 network on your boat, it should already be connected to power. Do not connect the included NMEA 2000 power cable to an existing NMEA 2000 network.

**NOTE:** The diagram shows only the NMEA 2000 data connection to the GPSMAP 4000/5000 series chartplotter. The chartplotter must also be connected to power or it will not function. See [page 9](#).

**NOTE:** One GPS antenna will provide position data for every device on the NMEA 2000 network. Do not connect multiple GPS antennas if you are using multiple chartplotters.

## Creating a basic NMEA 2000 Network

If your boat does not already have an existing NMEA 2000 network installed, you will need to create a basic NMEA 2000 network. For more information on NMEA 2000, visit [www.garmin.com](http://www.garmin.com).

### To create a basic NMEA 2000 network

1. Connect the three included T-connectors together by their sides.
2. Connect the appropriate terminators to each end of the combined T-connectors.
3. Wire the included NMEA 2000 power cable to a 12 Vdc power source through a switch. Connect to the ignition switch for the boat if possible.
4. Connect the NMEA 2000 power cable to the top of one of the T-connectors.
5. Route and connect the included NMEA 2000 drop cables from the GPS 17x and from the GPSMAP 4000/5000 series chartplotter to the tops of the other T-connectors.

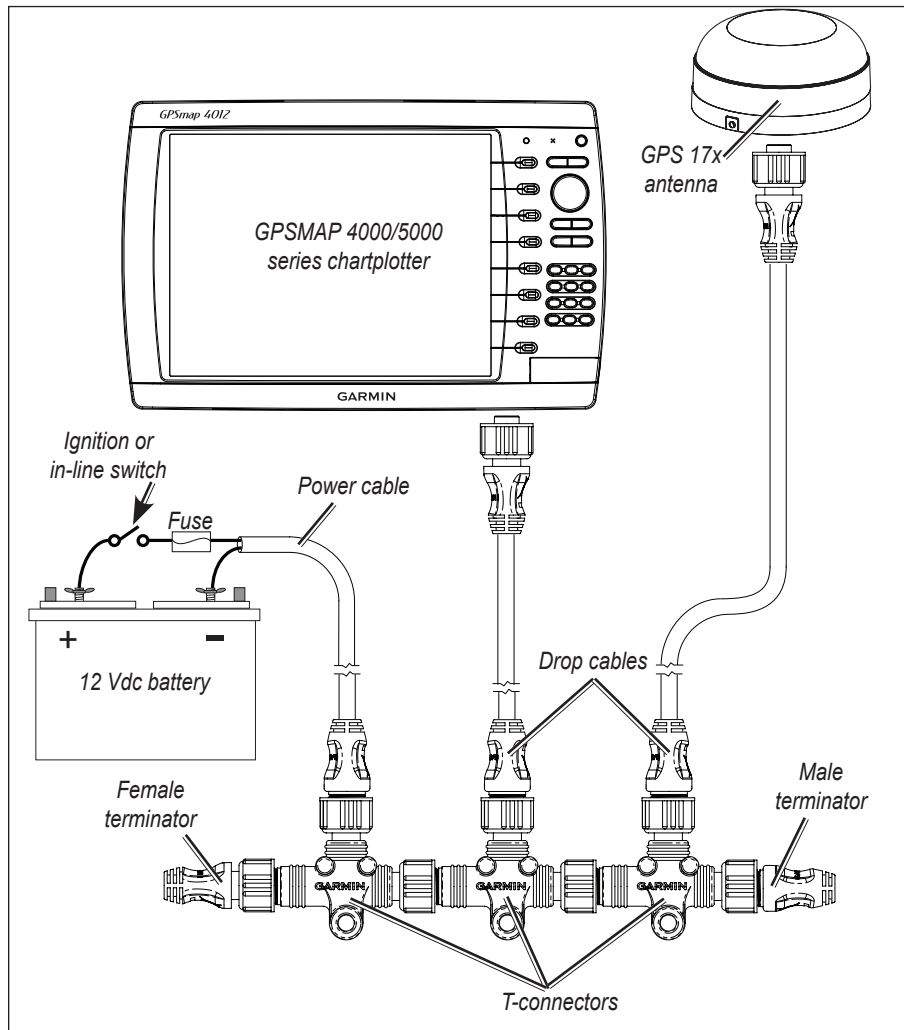

**Creating a Basic NMEA 2000 Network**

**NOTE:** The diagram shows only the NMEA 2000 data connection to the GPSMAP 4000/5000 series chartplotter. The chartplotter must also be connected to power or it will not function. See [page 9](#).

**NOTE:** One GPS antenna will provide position data for every device on the NMEA 2000 network. Do not connect multiple GPS antennas if you are using multiple chartplotters.

## Wiring a Garmin Marine Network

The optional Garmin Marine Network is a plug-and-play system that allows for high-speed data transfer between multiple Garmin chartplotters and other network-compatible Garmin devices such as a Garmin sonar unit (GSD 22), a Garmin radar (GMR 18 or GMR 404/406), or an XM Weather receiver (GDL30/30A). The GPSMAP 4000/5000 series chartplotters have three network ports that can be used to connect other Garmin network-compatible chartplotters and devices. If the network requires more ports, use a Garmin Marine Network port extender (GMS 10), or another GPSMAP 4000/5000. Data from each connected component is shared by all the connected Garmin chartplotters.

### Notes:

- NMEA 0183 devices must all be wired to one chartplotter on the network. The data is then shared over the network to other connected chartplotters.
- Connect all chartplotters to the NMEA 2000 network as well as to the Garmin Marine Network. NMEA 2000 data is not shared over the Garmin Marine Network.
- Connect network components, such as a Garmin GMR radar, GSD sounder, or GDL XM Weather receiver to any chartplotter on the network or to an optional GMS 10 Network Port Expander. Data is shared between all chartplotters on the network.
- BlueChart® g2 Vision cartography data is shared with any connected GPSMAP 4000/5000 series chartplotter.
- Video input(s) from the Marine Video cable is only viewable on the chartplotter to which it is connected.
- You can connect a GPSMAP 4000/5000 chartplotter to a Marine Network with a GPSMAP 3000 series chartplotter:
  - They will share GPS 17 GPS position information as well as information to and from standard NMEA 0183 devices.
  - They will share information from connected network compatible Garmin devices such as a sonar unit (GSD 22), a radar (GMR 18 or GMR 404/406), or an XM Weather receiver (GDL30/30A).
  - Garmin GPSMAP 3000 series chartplotters CANNOT share cartography data with the GPSMAP 4000/5000 series chartplotters.
- All network components must be connected to the power source for the boat according to their installation instructions. The following diagrams show only the network connections, not power connections.
- Currently, XM Weather and audio service is only available in the United States (lower 48). Because of this, a connected XM Weather receiver (GDL30/30A) will only function in the United States (lower 48).

### The Garmin Marine Network Cable:

- The Garmin Marine Network Cable has a locking ring that secures the cable to the chartplotter or marine network device. Because of the size of this locking ring, it is not connected to the network cable at the factory to make it easier to install on your boat.
- After the cable is run to the chartplotter or network device, snap the locking ring together around the connector and insert the rubber washer as indicated on the instructions packaged with the cable.



## Sample Garmin Marine Network Setups:

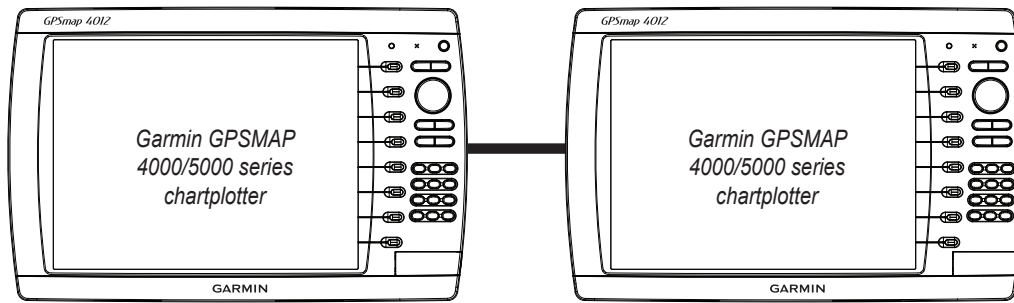

**Marine Network with Two Chartplotters**

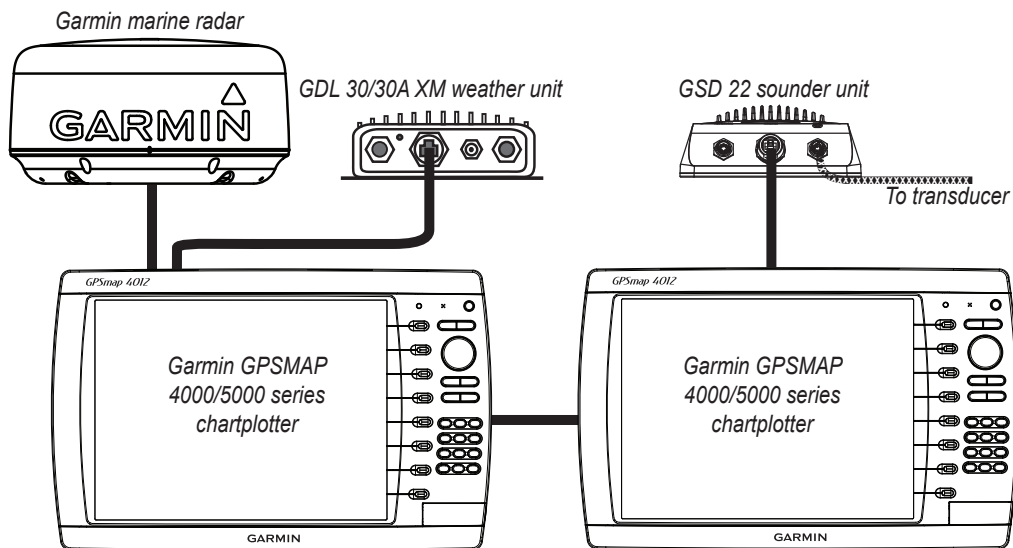

**Extended Marine Network With Two Chartplotters**

**NOTE:** Every device connected to the Garmin Marine Network must be connected to the power supply for the boat. These diagrams show the network connections; however, they do not show the power connections. Wire each device according to the appropriate installation instructions.

**NOTE:** These diagrams show the Garmin Marine Network connections; however, they do not show NMEA 2000 or NMEA 0183 connections.

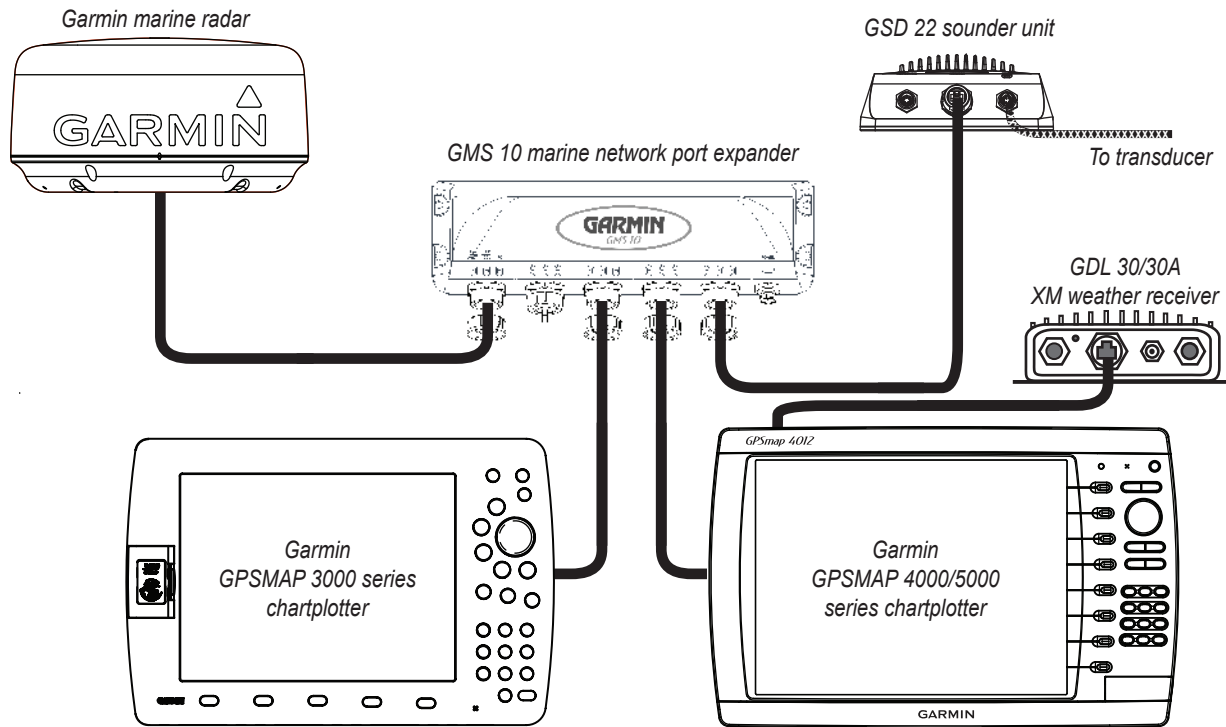

**Connecting a GPSMAP 4000/5000 Series Chartplotter to an Existing Garmin Marine Network**

- 
- NOTE:** When connecting a GPSMAP 4000/5000 series chartplotter to an existing Garmin Marine Network, the GMS 10 can be used but is not necessary. The GPSMAP 4000/5000 series chartplotter has three network ports and acts as a port expander. Wire the GPS antenna and additional NMEA devices to either the existing GPSMAP 3000 series chartplotter or the new GPSMAP 4000/5000 Series chartplotter. The existing GPSMAP 3000 series chartplotter and the new GPSMAP 4000/5000 series chartplotter share NMEA 0183 data and Garmin Marine Network data, but do not share cartography.

---

  - NOTE:** Every device connected to the Garmin Marine Network must be connected to the power supply for the boat. This diagram shows the network connections; however, it does not show the power connections. Wire each device according to the appropriate installation instructions.

---

  - NOTE:** This diagram shows the Garmin Marine Network connections; however, it does not show NMEA 2000 or NMEA 0183 connections.

---

## Wiring Additional NMEA 0183 Devices

The NMEA 0183 data cable included with the GPSMAP 4000/5000 series chartplotter supports the NMEA 0183 standard, which is used to wire various NMEA 0183-compliant devices, such as VHF radios, NMEA instruments, autopilots, or a computer.

### Basic NMEA 0183 Wiring

These diagrams illustrate basic NMEA 0183 wiring used to connect your GPSMAP 4000/5000 series chartplotter to NMEA 0183-compliant devices such as an AIS or DSC device. For more-complete information on the NMEA 0183 capabilities of the GPSMAP 4000/5000 series chartplotter, see the section on advanced NMEA 0183 wiring ([page 16](#)).

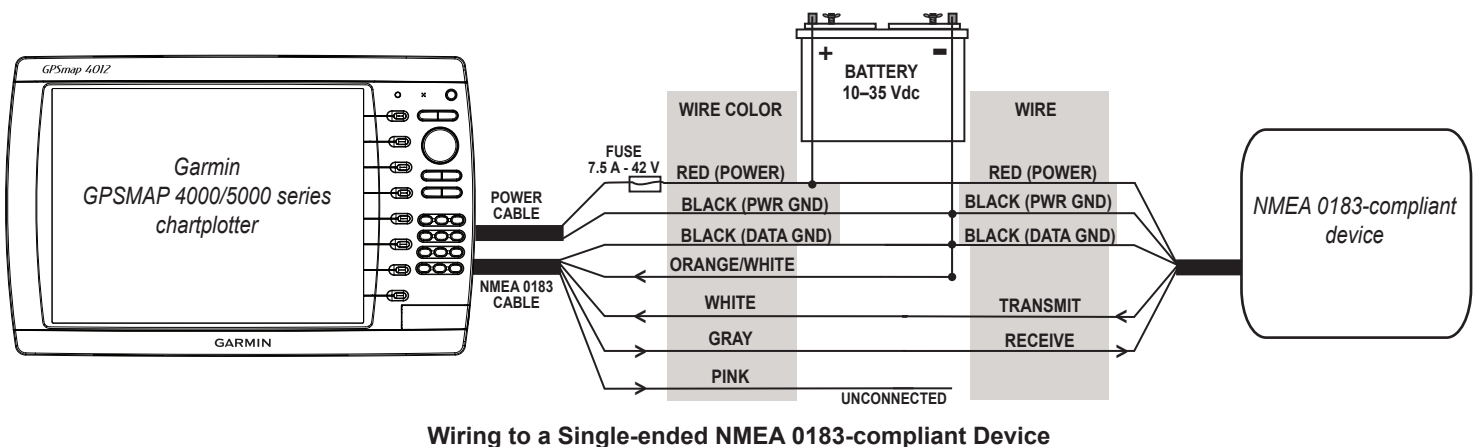
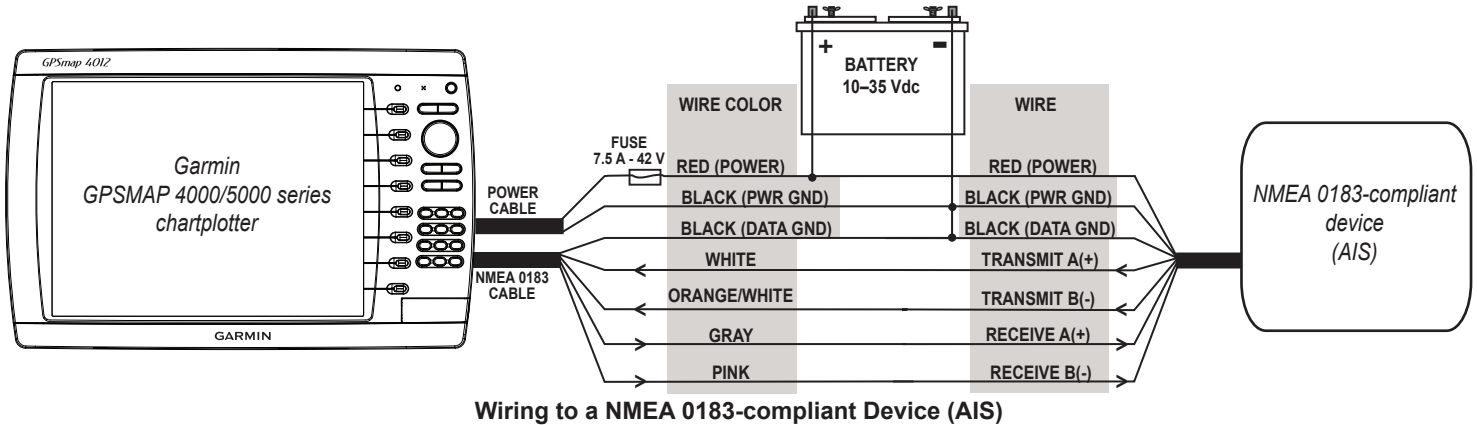

#### Notes:

- If the NMEA 0183-compliant device has only one receiving wire (no A, B, +, or -), leave the **pink** wire unconnected.
- If the NMEA 0183-compliant device has only one transmitting wire (no A, B, +, or -), connect the **orange/white** wire to ground.
- Consult the installation instructions of your NMEA 0183-compliant device to identify the Transmit A(+) and B(-) wires and Receive A(+) and B(-) wires.
- Use 28 AWG, shielded, twisted-pair wiring for extended runs of wire.
- Solder all connections and seal the connection with heat-shrink tubing.

## Advanced NMEA 0183 Wiring

The GPSMAP 4000/5000 series chartplotter features four ports to receive NMEA 0183 data (RX ports), and two ports to send NMEA 0183 data (TX ports). Wire one NMEA 0183 device per RX port to send data to a 4000/5000 series chartplotter, wire up to three NMEA 0183 devices in parallel to each TX port to receive data from a 4000/5000 series chartplotter.

Each RX and TX port has 2 wires, labeled A (+) and B (-) according to the NMEA 0183 convention. Connect the corresponding A (+) and B (-) wires of each port to the A (+) and B (-) wires of your NMEA 0183-compliant device. Refer to the table and wiring diagrams when wiring the 4000/5000 chartplotter to NMEA 0183 devices.

**Consult the installation instructions of your NMEA 0183-compliant device to identify the Transfer (TX) A(+) and B(-) wires and Receiving (RX) A(+) and B(-) wires.** Use 28 AWG, shielded, twisted-pair wiring for extended runs of wire. Solder all connections and seal the connection with heat-shrink tubing.

### Notes:

- For two-way communication with a NMEA 0183 device, the ports on the GPSMAP 4000/5000 chartplotters are not linked. For example, if the RX port of the NMEA-compliant device is wired to TX port 1 on the GPSMAP 4000/5000, you can wire the TX port of your NMEA 0183-compliant device to RX port 1, port 2, port 3, or port 4 on the GPSMAP 4000/5000.
- The ground wires on the NMEA 0183 data cable from the GPSMAP 4000/5000 series chartplotter and your NMEA 0183-compliant device must both be grounded.
- Approved NMEA 0183 sentences—GPBWC, GPRMC, GPGGA, GPGSA, GPGSV, GPGLL, GPBOD, GPRMB, GPRTE, GPVTG, GPWPL, GPXTE, and Garmin proprietary sentences—PGRME, PGRMM, and PGRMZ.
- The GPSMAP 4000/5000 series chartplotter also includes support for the WPL sentence, DSC, and sonar NMEA 0183 input with support for the DPT (depth) or DBT, MTW (water temperature), and VHW (water temperature, speed, and heading) sentences.
- Use the Communications section of the Configure menu on the GPSMAP 4000/5000 series chartplotter to set up NMEA 0183 communications. See the owner's manual for details.

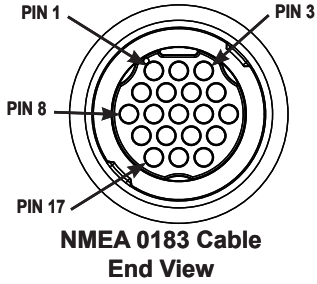
Port	Wire Function	Wire Color	Pin Number	Connector
Receiving Port 1	RX / A (+)	White	1	 <p style="text-align: center;"><b>NMEA 0183 Cable End View</b></p>
	RX / B (-)	Orange/White	2	
Receiving Port 2	RX / A (+)	Brown	5	
	RX / B (-)	Brown/White	6	
Receiving Port 3	RX / A (+)	Violet	9	
	RX / B (-)	Violet/White	10	
Receiving Port 4	RX / A (+)	Black/White	11	
	RX / B (-)	Red/White	12	
Transmitting Port 1	TX / A (+)	Gray	3	
	TX / B (-)	Pink	4	
Transmitting Port 2	TX / A (+)	Blue	7	
	TX / B (-)	Blue/White	8	
N/A	GPS 17 IN	Green/White	13	
N/A	GPS 17 OUT	Green	14	
N/A	SPARE		15	
N/A	ALARM	Yellow	16	
N/A	ACCESSORY ON	Orange	17	
N/A	GROUND	Black	18	
N/A	SPARE		19	

**GPSMAP 4000/5000 Series NMEA 0183 Data Cable**

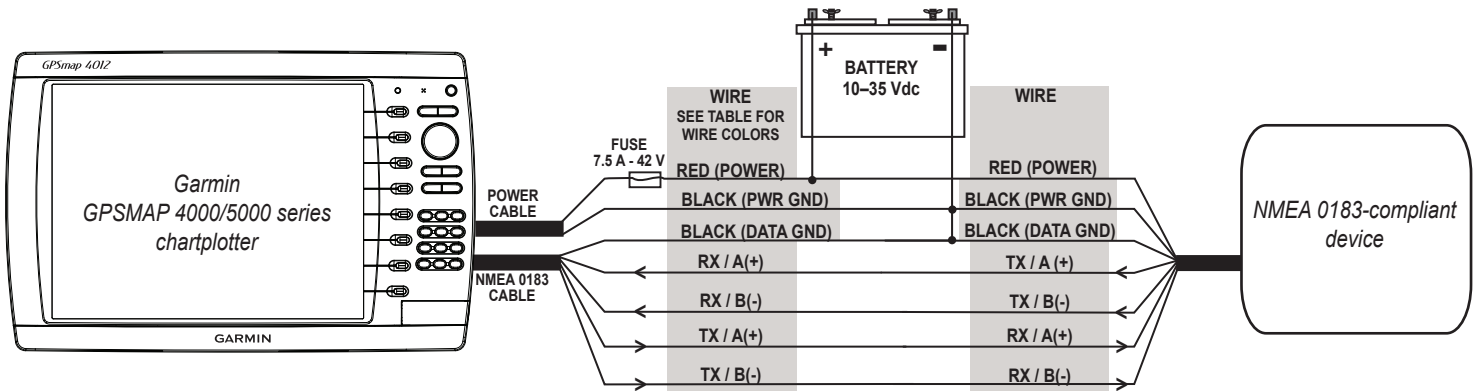

**Wiring to a Standard NMEA 0183-compliant Device with 2-way Communication**

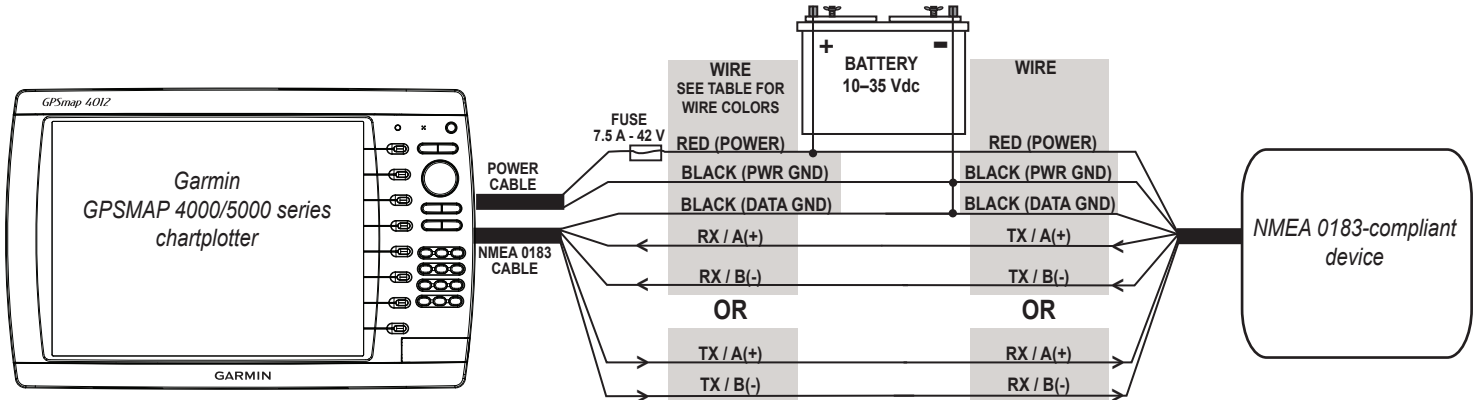

**Wiring to a Standard NMEA 0183-compliant Device for One-Way Communication**

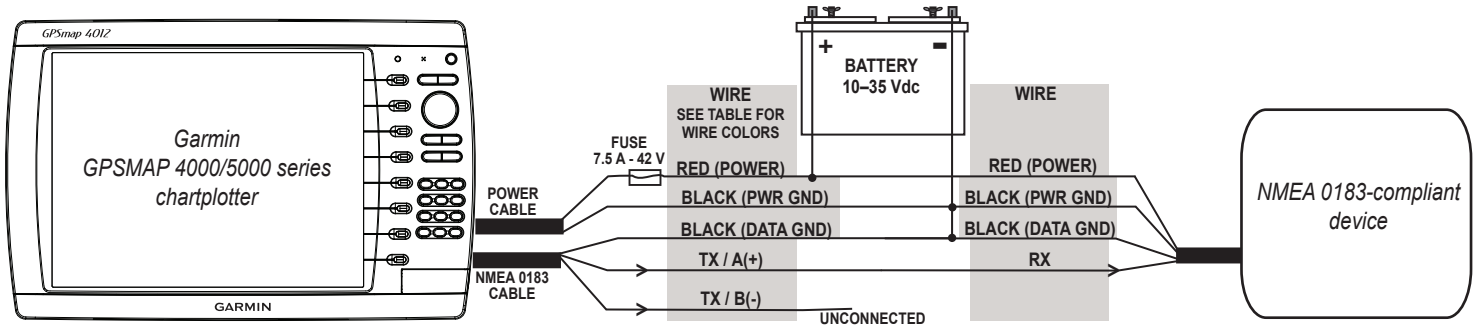

**Wiring to Send Data to a NMEA 0183-compliant Device With a Single Wire TX Connection**

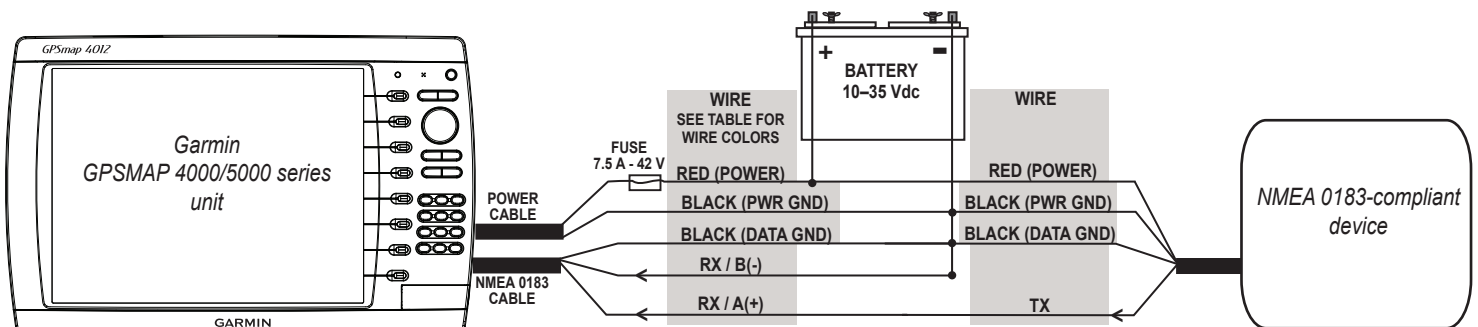

**Wiring to Receive Data from a NMEA 0183-compliant Device With a Single Wire RX Connection**

## Wiring to an Optional Alarm

The GPSMAP 4000/5000 series chartplotter can be used with a lamp, a horn, or both, to sound or flash an alert when the chartplotter displays a message. The alarm does not need to be wired for the GPSMAP 4000/5000 chartplotter to function. The alarm circuit switches to a low-voltage state when the alarm sounds. The maximum current is 100 mA, and a relay is needed to limit the current from the chartplotter to 100 mA. To select between visual and audible alerts, install a switch.

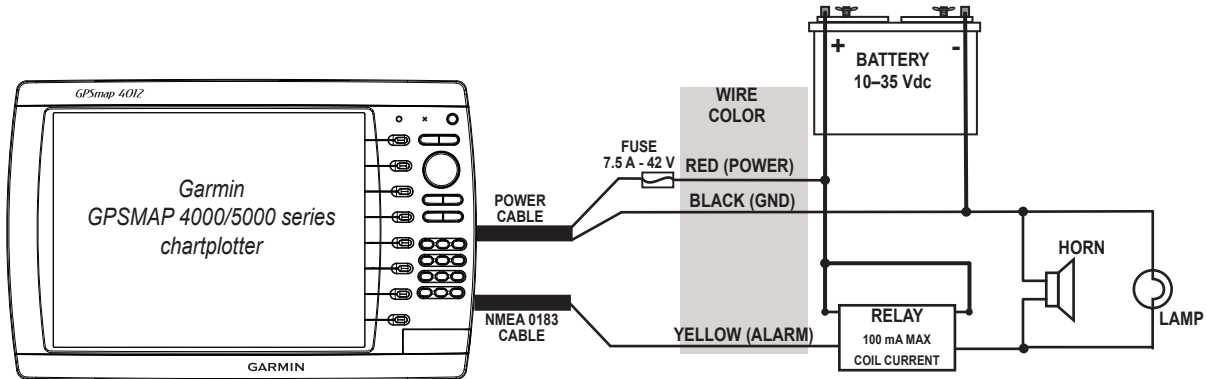

Wiring to a lamp, a horn, or both.

## Wiring to a DB-9 PC Serial Connector

The GPSMAP 4008/4208/4010/4210/4012/4212/5008/5208/5012/5212 chartplotters can be connected to a PC with a serial port by wiring the chartplotter to a DB-9 serial connector.

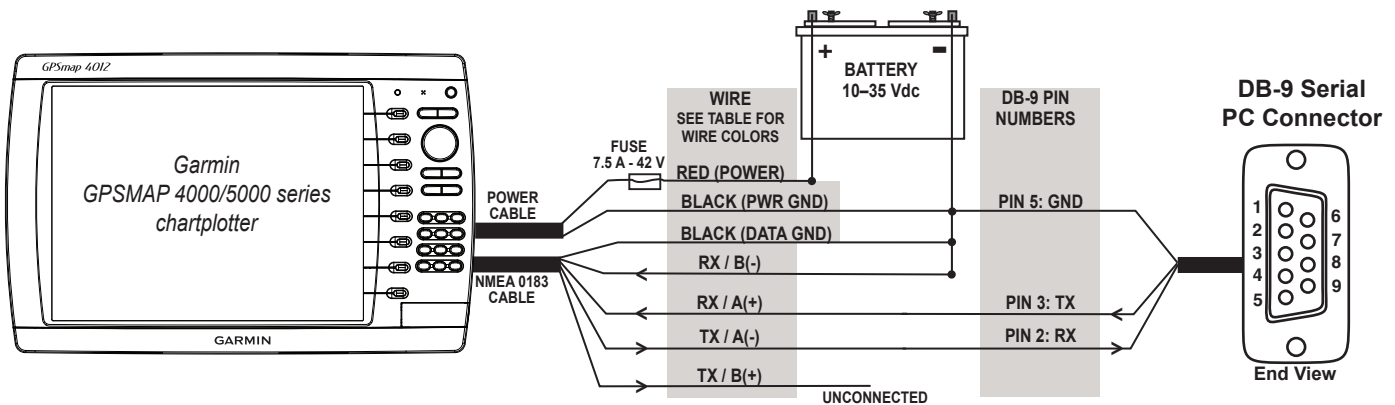

Wiring to a DB-9 Serial PC Connector

## Marine Video Cable

The included Marine Video 17-pin cable allows input of NTSC (National Television System Committee)/PAL (Phase Alternate Line) composite video sources, and PC monitor output (4008/4208/4010/4210/5008/5208 = VGA output, 4012/4212/5012/5212/5015/5215 = XGA output).

Marine Video inputs are only available on the chartplotter to which they are attached and will not transmit over the Garmin Marine Network.

- ① and ② VIDEO 1 and VIDEO 2 Inputs (RCA connectors) allow input from two separate NTSC/PAL compatible video devices, such as VCR, DVD, TV, or a video camera. The chartplotter can display one video input at a time or alternate between the two. See the owner's manual for details. Sound from a video source must be attached to a separate stereo/audio system. The video output from video device attaches to the Video 1 (Black Cable) or Video 2 (Gray Cable) RCA connectors.
- ③ Use the PC monitor output (HD 15-pin) connector for remote viewing of the chartplotter display on a computer monitor. The remote monitor must be capable of at least VGA resolution and have multi-sync capability.

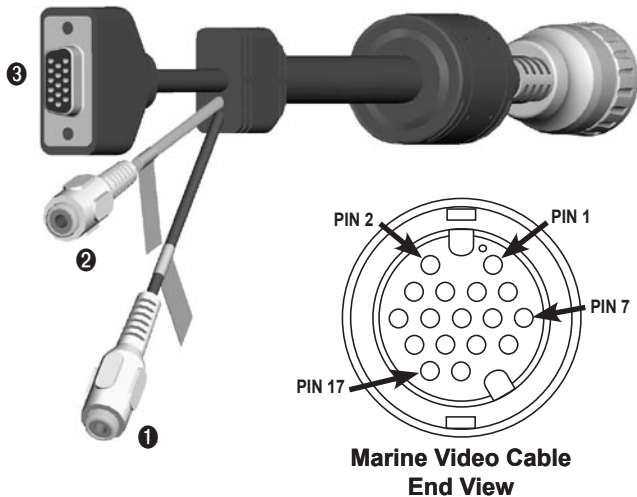

Note	Connector	Pin	Function
①	RCA-1 CENTER	2	VIDEO 1 IN (BLACK JACKET)
	RCA-1 OUTER	6	VIDEO 1 IN, GND
②	RCA-2 CENTER	11	VIDEO 2 IN (GRAY JACKET)
	RCA-2 OUTER	15	VIDEO 2 IN, GND
③	HD-15 PIN 1	1	VGA, ANALOG-RED
	HD-15 PIN 2	4	VGA, ANALOG-GREEN
	HD-15 PIN 3	3	VGA, ANALOG-BLUE
	HD-15 PIN 5	13	VGA, ANALOG, GND
	HD-15 PIN 6	8	VGA, ANALOG-RED, GND
	HD-15 PIN 7	8	VGA, ANALOG-GREEN, GND
	HD-15 PIN 8	8	VGA, ANALOG-BLUE, GND
	HD-15 PIN 10	13	VGA, SYNC-GND
	HD-15 PIN 13	7	VGA, H-SYNC
	HD-15 PIN 14	12	VGA, V-SYNC
	HD-15 PIN SHELL	9	VGA, OVERALL SHIELD

## Making the Final Connections to the GPSMAP 4000/5000 Series Chartplotter

After the power cable and the GPS antenna (as well as any optional Garmin Marine Network devices, NMEA 0183 devices, NMEA 2000 connections, or video connections) are wired to the boat, the cables must be connected to the GPSMAP 4000/5000 series chartplotter.

There are seven connectors on the back of the chartplotter, one for power, three for Garmin Marine Network devices, one for the NMEA 0183 cable, one for a NMEA 2000 cable, and one for the marine video cable.

To attach the power cable, the NMEA 0183 cable, and the marine video cable, carefully press the cable into the correct port on the back of the chartplotter until it is firmly seated. **Do not force the cable, because this may damage the pins.** After the cable is seated, turn the locking ring clockwise until it stops.

To attach a Garmin Marine Network cable or a NMEA 2000 Micro-connector cable, carefully press the cable into the correct port on the back of the chartplotter until it is firmly seated. **Do not force the cable, because this may damage the pins.** After the cable is seated, turn the locking ring clockwise until it is tight. Be careful not to overtighten the locking ring.

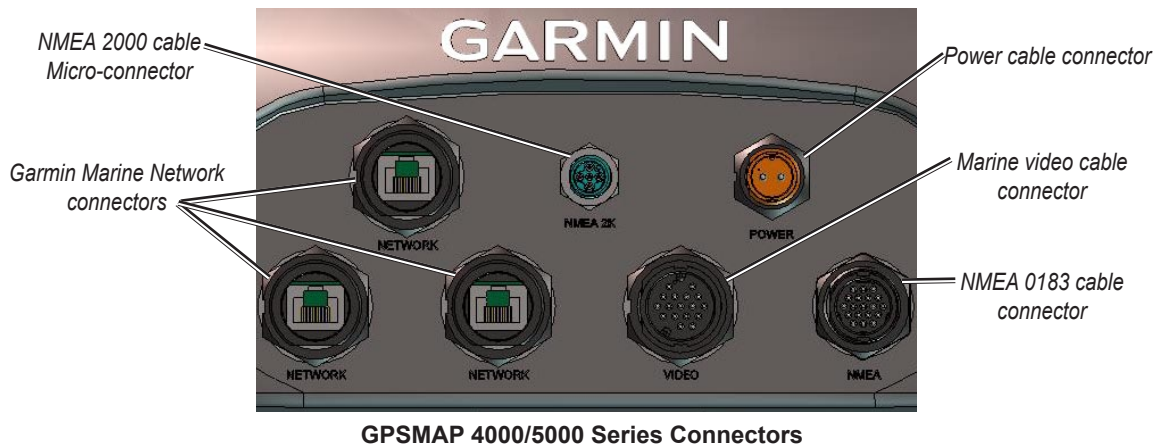

## Updating the Chartplotter Software

Your GPSMAP 4000/5000 series chartplotter may contain a software update SD card. If so, follow the instructions provided with the card.

If a software update SD card is not included, visit [www.garmin.com](http://www.garmin.com) to make sure your chartplotter software is up-to-date. To determine the version of software on your chartplotter, select or touch **Configure > System > System Information**.

# Specifications

## Physical Specifications

<b>Size:</b>	GPSMAP 4008:	7 in. H × 11 <sup>13</sup> / <sub>64</sub> in. W × 4 <sup>13</sup> / <sub>64</sub> in. D (176.9 × 284.4 × 106 mm)
	GPSMAP 4010:	8 <sup>29</sup> / <sub>32</sub> in. H × 13 <sup>13</sup> / <sub>32</sub> in. W × 4 <sup>1</sup> / <sub>8</sub> in. D (226.9 × 340.4 × 105.1 mm)
	GPSMAP 4012:	9 <sup>1</sup> / <sub>2</sub> in. H × 14 <sup>51</sup> / <sub>64</sub> in. W × 4 <sup>1</sup> / <sub>8</sub> in. D (240.5 × 375 × 105.1 mm)
	GPSMAP 5008:	6 <sup>51</sup> / <sub>64</sub> in. H × 10 <sup>3</sup> / <sub>32</sub> in. W × 4 <sup>11</sup> / <sub>64</sub> in. D (173.5 × 256 × 105.9 mm)
	GPSMAP 5012:	9 <sup>15</sup> / <sub>32</sub> in. H × 13 in. W × 4 <sup>45</sup> / <sub>64</sub> in. D (240.5 × 330 × 119.2 mm)
	GPSMAP 5015:	11 <sup>21</sup> / <sub>32</sub> in. H × 15 <sup>35</sup> / <sub>64</sub> in. W × 5 <sup>21</sup> / <sub>32</sub> in. D (295.8 × 394.9 × 143.8 mm)
<b>Weight:</b>	GPSMAP 4008:	6 lb. (2.7 kg)
	GPSMAP 4010:	8 lb. (3.6 kg)
	GPSMAP 4012:	10 lb. (4.5 kg)
	GPSMAP 5008:	6 lb. (2.7 kg)
	GPSMAP 5012:	10 lb. (4.5 kg)
	GPSMAP 5015:	12 lb. (5.4 kg)

<b>Display:</b>	GPSMAP 4008:	5 <sup>11</sup> / <sub>64</sub> in. H × 6 <sup>27</sup> / <sub>32</sub> in. W (131.4 × 174 mm)
	GPSMAP 4010:	6 <sup>11</sup> / <sub>32</sub> in. H × 8 <sup>7</sup> / <sub>16</sub> in. W (161.4 × 214.2 mm)
	GPSMAP 4012:	7 <sup>19</sup> / <sub>64</sub> in. H × 9 <sup>11</sup> / <sub>16</sub> in. W (184.3 × 245.8 mm)
	GPSMAP 5008:	5 in. H × 6 <sup>47</sup> / <sub>64</sub> in. W (128.2 × 170.9 mm)
	GPSMAP 5012:	7 <sup>7</sup> / <sub>64</sub> in. H × 9 <sup>19</sup> / <sub>64</sub> in. W (180.49 × 235.97 mm)
	GPSMAP 5015:	8 <sup>63</sup> / <sub>64</sub> in. H × 11 <sup>31</sup> / <sub>32</sub> in. W (228.1 × 304.1 mm)

**Case:** Fully Gasketed, high-impact plastic and aluminum alloy, waterproof to IEC 529-IPX

**Temp. Range:** from 5°F to 131°F (from -15°C to 55°C)

<b>Compass Safe Distance:</b>	GPSMAP 4008/5008:	31 <sup>1</sup> / <sub>2</sub> in. (80 cm)
	GPSMAP 4012/5012:	39 <sup>3</sup> / <sub>8</sub> in. (1 m)
	GPSMAP 4010/4210:	31 <sup>1</sup> / <sub>2</sub> in. (80 cm)
	GPSMAP 5015:	23 <sup>5</sup> / <sub>8</sub> in. (60 cm)

## Power

**Source:** 10–35 Vdc

**Usage:** GPSMAP 4008/5008: 35 W max. at 10 Vdc

## NMEA 2000 PGN Information

Receive		Transmit	
059392	ISO Acknowledgment	059392	ISO Acknowledgment
059904	ISO Request	059904	ISO Request
060928	ISO Address Claim	060928	ISO Address Claim
126208	NMEA - Command/Request/Acknowledge Group Function	126208	NMEA - Command/Request/Acknowledge Group Function
126464	Transmit/Receive PGN List Group Function	126464	Transmit/Receive PGN List Group Function
126992	System Time	126996	Product Information
126996	Product Information	127250	Vessel Heading
127250	Vessel Heading	128259	Speed - Water Referenced
127489	Engine Parameters - Dynamic	128267	Water Depth
127488	Engine Parameters - Rapid Update	129025	Position - Rapid Update
127505	Fluid Level	129026	COG & SOG - Rapid Update
128259	Speed - Water Referenced	129029	GNSS Position Data
128267	Water Depth	129540	GNSS Sats in View
129025	Position - Rapid Update	130306	Wind Data
129026	COG & SOG - Rapid Update	130312	Temperature
129029	GNSS Position Data		
129539	GNSS DOPs		
129540	GNSS Sats in View		
130306	Wind Data		
130310	Environmental Parameters		
130311	Environmental Parameters		
130312	Temperature		
130313	Humidity		
130314	Actual Pressure		



GPSMAP 4000/5000 series chartplotters are NMEA 2000 certified.



## GPS 17 Antenna Drilling Template

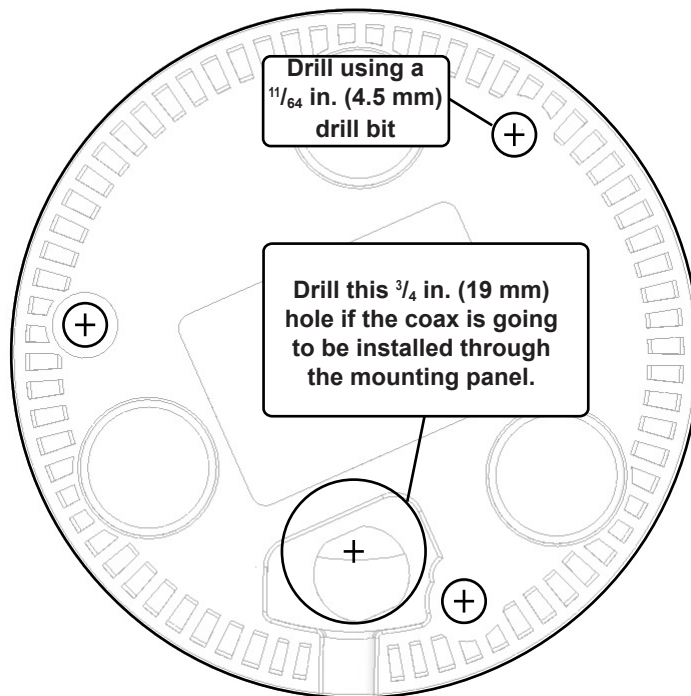

**WARNING:** Do not use this template to mount the GPS 17x antenna. This template is designed for the GPS 17 antenna only. To mount a GPS 17x antenna, use the surface-mount bracket as the template. See [page 7](#) for more information.



© Copyright 2007, 2008 Garmin Ltd. or its subsidiaries

Garmin International, Inc.

1200 E 151st Street, Olathe, Kansas 66062 USA

Tel. 913/397.8200

Fax. 913/397.8282

Garmin (Europe) Ltd

Liberty House, Hounslow Business Park, Southampton, Hampshire, SO40 9RB UK.

Tel. 44/0870.8501241 (outside the UK.) or 0808 2380000 (UK only)

Fax. 44/0870.8501251

Garmin Corporation

No. 68, Jangshu 2nd Road, Shijr, Taipei County, Taiwan

Tel. 886/2.2642.9199

Fax. 886/2.2642.9099

Part Number 190-00779-02 Rev. D